



**STRONG PARTNERS.  
TOUGH TRUCKS.™**

# **S80-120FT SERIES TECHNICAL GUIDE**

**[WWW.HYSTER.COM](http://WWW.HYSTER.COM)**

# > S80FT DIMENSIONS

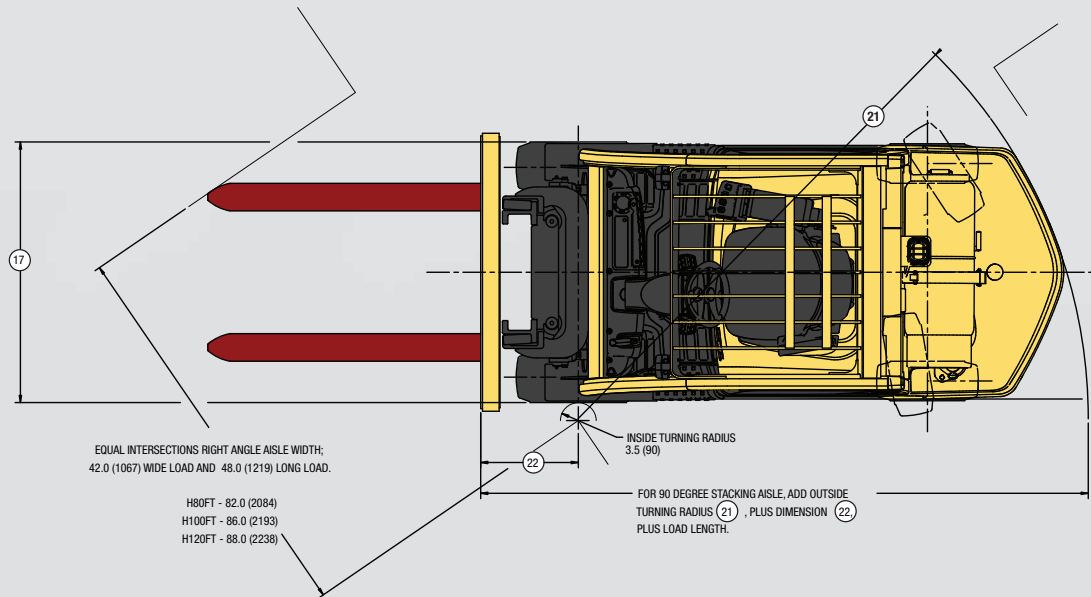

Seat Type	Standard OHG	Optional OHG
Non-Suspension	42.0 (1068)	39.4 (1001)
Semi-Suspension	42.5 (1080)	39.9 (1013)
Full-Suspension	41.8 (1062)	N/A
Swivel Full-Suspension	42.0 (1068)	N/A

TRUCK MODEL	C	D	E	T	X
	in (mm)	percent	degrees	in (mm)	in (mm)
S80FT	24.1 (613)	40%	22.7	4.4 (112)	28.1 (714)

Seat in depressed position

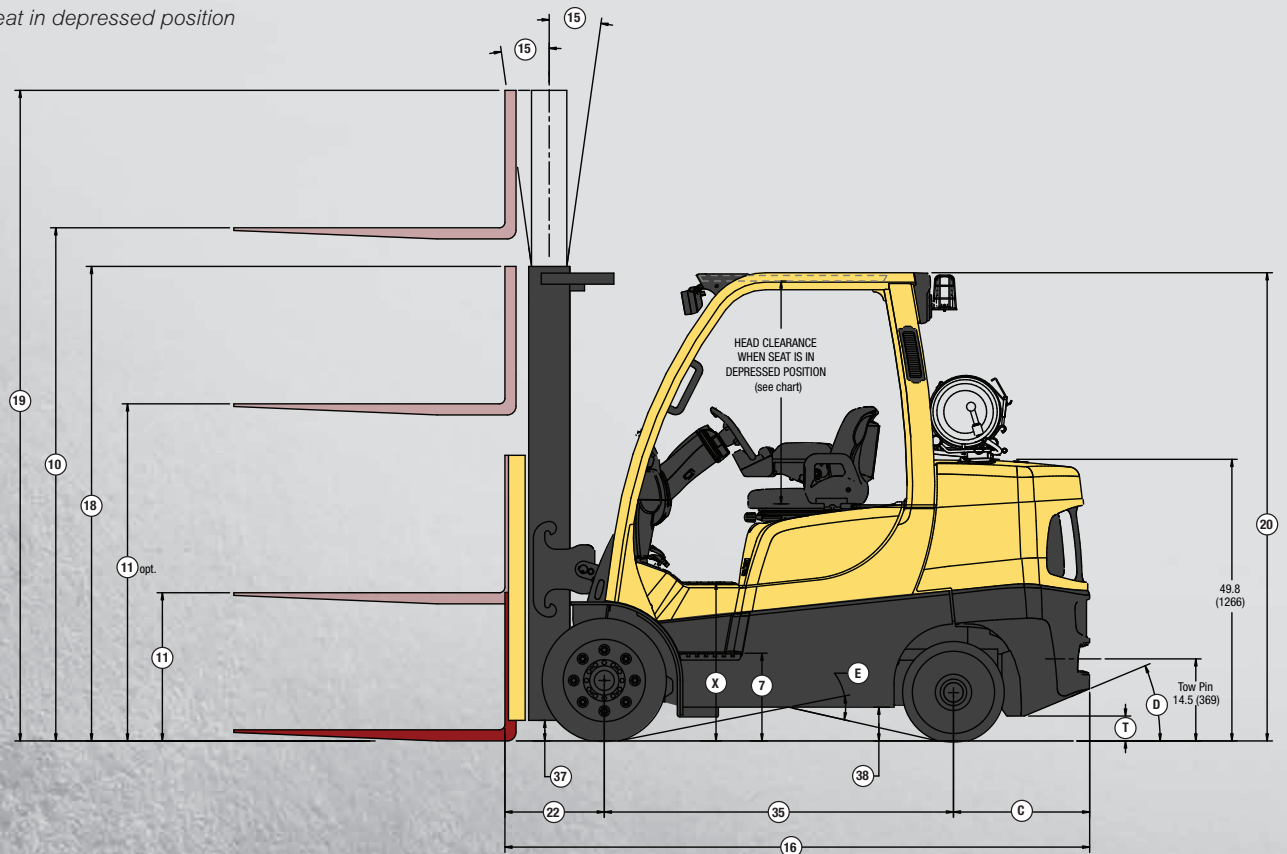

Circled dimensions correspond to the line numbers on the tabulated chart inside the Technical Guide. Dimensions are in inches (millimeters).

# S80FT SPECIFICATIONS <

GENERAL	1	Manufacturer Name		Hyster Company		
	2	Model		S80FT		
		Engine		Kubota 3.8L LPG		
	3	Rated Capacity	lb (kg)	8000 (3629)		
	4	Load Center, Distance	in (mm)	24 (610)		
	5	Power Type		LPG		
	6	Operator Type		Sit-Down Rider		
	7	Step Height	in (mm)	15.6 (396)		
	8	Tire Type - Cushion, Solid, Pneumatic		Cushion		
DIMENSIONS	9	Wheels, Number - Front/ Rear	X driven	2x/2		
	10	Lift Height, Top of Fork (TOF)	in (mm)	120 (3050)		
	11	Lift Heights, Standard Limited Free Lift (LFL) with LBR (TOF)	in (mm)	6 (150)		
		Lift Heights, Optional Full Free Lift (FFL) with LBR (TOF)	in (mm)	35 (900)		
	12	Standard Carriage Width	in (mm)	42 (1067)		
	13	Forks, Thickness x Width x Length	in (mm)	2 X 5 X 48 (50 X 125 X 1219)		
	14	Fork Spread, Outside Dimensions	in (mm)	38.3 (972)		
	15	Mast Tilt Angles, Forward/Backward	degrees	5F/6B		
	16	Length To Face of Forks	in (mm)	103.5 (2630)		
	17	Overall Width, Standard Tread	in (mm)	46.1 (1170)		
		Overall Width, Wide Tread	in (mm)	50.0 (1270)		
	18	Height, Standard Mast - Lowered	in (mm)	84 (2134)		
	19	Height, Standard Mast - Extended with LBR	in (mm)	169 (4284)		
		Height, Standard Mast - Extended without LBR	in (mm)	149 (3783)		
	20	Height, Standard Overhead Guard	in (mm)	86 (2171)		
		Height, Optional Overhead Guard	in (mm)	83 (2104)		
	21	Turning Radius, Minimum Outside (OTR)	in (mm)	90.5 (2298)		
	22	Length, Center of Wheel to Face of Forks	in (mm)	17.6 (447)		
	23	Aisle Width, Right Angle Stack (Add Length of Load)	in (mm)	108.1 (2746)		
	24	Equal Aisle, 90-Degree Intersecting Aisle (48" L X 40" W Load)	in (mm)	81.7 (2075)		
	PERFORMANCE <sup>†</sup>	25	Travel Speed RL/NL	1-Speed	mph (km/h)	10.7/10.7 (17.2/17.2)
				2-Speed	mph (km/h)	13.7/13.9 (22/22.4)
		26	Lift Speed, Standard 2-Stage LFL RL/NL		ft/min (m/s)	120/122 (.61/.62)
			Lift Speed, Optional 2-Stage FFL RL/NL		ft/min (m/s)	106/108 (.54/.55)
		Lift Speed, Optional 3-Stage FFL RL/NL		ft/min (m/s)	112/114 (.57/.58)	
27		Lowering Speed, Standard 2-Stage LFL RL/NL		ft/min (m/s)	93/108 (.47/.55)	
		Lowering Speed, Optional 2-Stage FFL RL/NL		ft/min (m/s)	71/98 (.36/.50)	
		Lowering Speed, Optional 3-Stage FFL RL/NL		ft/min (m/s)	87/104 (.44/.53)	
28		Max Drawbar Pull RL/NL	1-Speed	lb (kg)	7132/2878 (3235/1306)	
			2-Speed	lb (kg)	8563/2878 (3884/1306)	
		Drawbar Pull @ 1 mph RL/NL	1-Speed	lb (kg)	6173/2878 (2800/1306)	
			2-Speed	lb (kg)	7162/2878 (3249/1306)	
29	Max Gradeability RL/NL ††	1-Speed	%	37/23		
		2-Speed	%	46/23		
	Gradeability @ 1 mph RL/NL ††	1-Speed	%	31/23		
		2-Speed	%	37/23		
WT.	31	Weight, Standard Truck (Standard 2-Std. LFL) NL	lb (kg)	12650 (5738)		
		Weight, Standard Truck (Standard 2-Std. LFL) RL	lb (kg)	20650 (9367)		
	32	Axle Loading, Static Front/Rear NL	lb (kg)	4797/7853 (2176/3562)		
		Axle Loading, Static Front/Rear RL	lb (kg)	18182/2468 (8247/1119)		
TIRES & WHEELS	33	Tire Size, Front		22 X 9 X16		
	34	Tire Size, Rear		18 X 7 X 12.2		
	35	Wheelbase	in (mm)	61.8 (1570)		
	37	Ground Clearance, Lowest Point NL (with RL subtract -6mm)	in (mm)	4.5 (114)		
	38	Ground Clearance, Center of Wheelbase NL	in (mm)	6.0 (152)		
	39	Service Brake - Method of Control/Operation		Foot/Hydraulic		
40	Parking Brake - Method of Control/Operation		Hand/Mechanical			
POWERTRAIN	41	Battery Type		Maintenance Free		
	42	Volts/Cold Cranking Amps	v/cca	12/475		
	43	Engine, Manufacturer/Model		Kubota WG3800 LPG		
	44	Permanent Output	hp (kW)	74 (55) @ 1800 RPM		
	45	Torque @ Rated RPM	ft/lbs (kg/m)	221 (300) @ 1000 RPM		
	46	Number of Cylinders/Displacement	No/cc (ci)	4/3769 (230)		
		Standard Speeds, Forward/Reverse		1/1		
	49	Hydraulic Tank - capacity (drain & refill)	gal (liter)	20.5 (77.7)		
	51	Auxiliary Hydraulic Pressure Relief for Attachments	PSI (Mpa)	2250 (15.5)		

**CERTIFICATION:** These Hyster lift trucks meet design specifications of Part II ANSI B56.1-1969, as required by OSHA Section 1910.178(a)(2) and also comply with Part III ANSI B56.1-revision in effect at time of manufacture. Certification of compliance with the applicable ANSI standards appears on the lift truck.

<sup>†</sup> NOTE: Performance specifications / ratings are for truck equipped as described under Standard Equipment in this Technical Guide. Performance specifications are affected by the condition of the vehicle and how it is equipped, as well as by the nature and condition of the operating area. Specifications are subject to change and the proposed application should be discussed with your authorized Hyster Company Dealer.

<sup>††</sup> Limited by traction. For further information on this dimension, please contact your local Hyster dealer.

RL = Rated Load, NL = No Load

# > S100-120FT DIMENSIONS

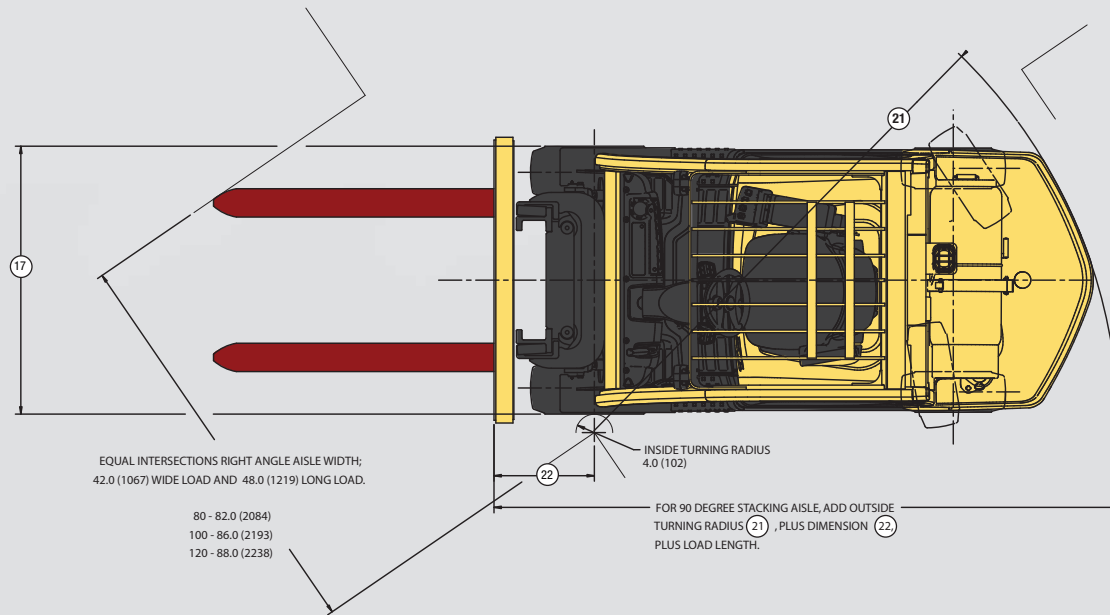

Seat Type	Standard OHG	Optional OHG
Non-Suspension	42.0 (1068)	39.4 (1001)
Semi-Suspension	42.5 (1080)	39.9 (1013)
Full-Suspension	41.8 (1062)	N/A
Swivel Full-Suspension	42.0 (1068)	N/A

TRUCK MODEL	C	D	E	T	X
	in (mm)	percent	degrees	in (mm)	in (mm)
<b>S100FT</b>	20.3 (517)	32%	20	4.6 (116)	28.3 (718)
<b>S120FT</b>	24.0 (609)	32%	21	4.6 (116)	28.3 (718)

Seat in depressed position

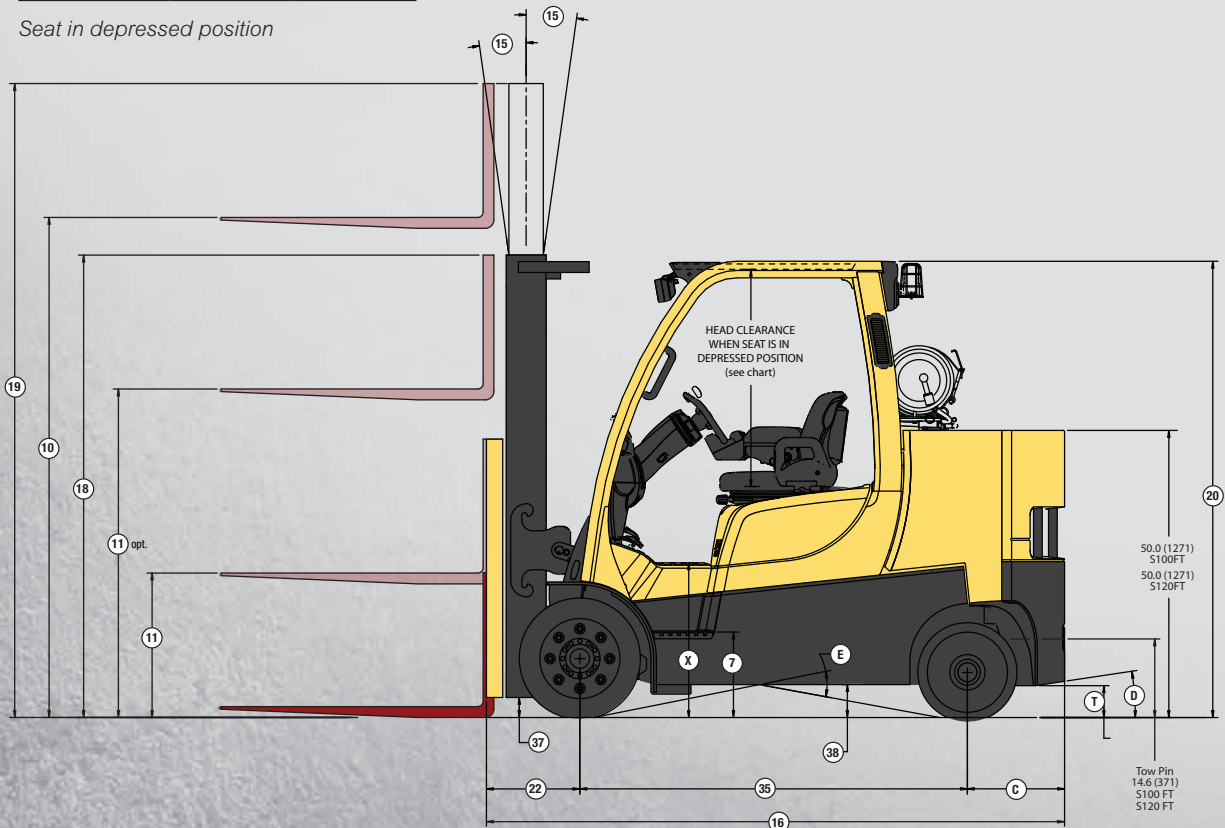

Circled dimensions correspond to the line numbers on the tabulated chart inside the Technical Guide. Dimensions are in inches (millimeters).

# S100FT SPECIFICATIONS <

GENERAL	1	Manufacturer Name		Hyster Company		
	2	Model		S100FT		
		Engine		Kubota 3.8L LPG		
	3	Rated Capacity	lb (kg)	10000 (4536)		
	4	Load Center, Distance	in (mm)	24 (610)		
	5	Power Type		LPG		
	6	Operator Type		Sit-Down Rider		
	7	Step Height	in (mm)	15.6 (396)		
	8	Tire Type - Cushion, Solid, Pneumatic		Cushion		
DIMENSIONS	9	Wheels, Number - Front/ Rear	X driven	2x/2		
	10	Lift Height, Top of Fork (TOF)	in (mm)	110 (2800)		
	11	Lift Heights, Standard Limited Free Lift (LFL) with LBR (TOF)	in (mm)	6 (150)		
		Lift Heights, Optional Full Free Lift (FFL) with LBR (TOF)	in (mm)	35 (907)		
	12	Standard Carriage Width	in (mm)	42 (1067)		
	13	Forks, Thickness x Width x Length	in (mm)	2 X 6 X 48 (50 X 150 X 1219)		
	14	Fork Spread, Outside Dimensions	in (mm)	38.3 (972)		
	15	Mast Tilt Angles, Forward/Backward	degrees	5F/6B		
	16	Length To Face of Forks	in (mm)	108.6 (2759)		
	17	Overall Width, Standard Tread	in (mm)	52.0 (1320)		
		Overall Width, Wide Tread	in (mm)	55.9 (1420)		
	18	Height, Standard Mast - Lowered	in (mm)	85 (2138)		
	19	Height, Standard Mast - Extended with LBR	in (mm)	159 (4031)		
		Height, Standard Mast - Extended without LBR	in (mm)	144 (3657)		
	PERFORMANCE†	20	Height, Standard Overhead Guard	in (mm)	86 (2175)	
			Height, Optional Overhead Guard	in (mm)	83 (2108)	
21		Turning Radius, Minimum Outside (OTR)	in (mm)	96.3 (2447)		
22		Length, Center of Wheel to Face of Forks	in (mm)	17.8 (452)		
23		Aisle Width, Right Angle Stack (Add Length of Load)	in (mm)	114.1 (2899)		
24		Equal Aisle, 90-Degree Intersecting Aisle (48" L X 40" W Load)	in (mm)	86.0 (2184)		
WT.		25	Travel Speed RL/NL 1-Speed	mph (km/h)	10.5/10.5 (16.9/17)	
			2-Speed	mph (km/h)	13.5/13.7 (21.7/22.1)	
		26	Lift Speed, Standard 2-Stage LFL RL/NL	ft/min (m/s)	110/112 (.56/.57)	
			Lift Speed, Optional 2-Stage FFL RL/NL	ft/min (m/s)	102/106 (.52/.54)	
			Lift Speed, Optional 3-Stage FFL RL/NL	ft/min (m/s)	106/108 (.54/.55)	
		27	Lowering Speed, Standard 2-Stage LFL RL/NL	ft/min (m/s)	100/83 (.51/.42)	
			Lowering Speed, Optional 2-Stage FFL RL/NL	ft/min (m/s)	89/63 (.45/.32)	
			Lowering Speed, Optional 3-Stage FFL RL/NL	ft/min (m/s)	93/77 (.47/.39)	
		TIRES & WHEELS	28	Max Drawbar Pull RL/NL 1-Speed	lb (kg)	7851/3803 (3561/1725)
				2-Speed	lb (kg)	9429/3803 (4277/1725)
	Drawbar Pull @ 1 mph RL/NL 1-Speed		lb (kg)	6732/3803 (3054/1725)		
	2-Speed		lb (kg)	7800/3803 (3538/1725)		
29	Max Gradeability RL/NL †† 1-Speed		%	33/26		
	2-Speed		%	40/26		
POWERTRAIN		Gradeability @ 1 mph RL/NL †† 1-Speed	%	28/26		
		2-Speed	%	32/26		
	31	Weight, Standard Truck (Standard 2-Stg. LFL) NL	lb (kg)	15329 (6953)		
		Weight, Standard Truck (Standard 2-Stg. LFL) RL	lb (kg)	25329 (11489)		
POWERTRAIN	32	Axle Loading, Static Front/Rear NL	lb (kg)	6339 / 8990 (2875 / 4078)		
		Axle Loading, Static Front/Rear RL	lb (kg)	22323 / 3006 (10126 / 1363)		
	33	Tire Size, Front		22 X 12 X16		
	34	Tire Size, Rear		18 X 8 X 12.2		
	35	Wheelbase	in (mm)	70.5 (1790)		
	37	Ground Clearance, Lowest Point NL (with RL subtract -6mm)	in (mm)	4.6 (118)		
	38	Ground Clearance, Center of Wheelbase NL	in (mm)	6.1 (156)		
	39	Service Brake - Method of Control/Operation		Foot/Hydraulic		
	40	Parking Brake - Method of Control/Operation		Hand/Mechanical		
	41	Battery Type		Maintenance Free		
42	Volts/Cold Cranking Amps	v/cca	12/475			
43	Engine, Manufacturer/Model		Kubota WG3800 LPG			
44	Permanent Output	hp (kW)	91 (69) @ 2400 RPM			
45	Torque @ Rated RPM	ft/lbs (kg/m)	221 (300) @ 1000 RPM			
46	Number of Cylinders/Displacement	No/cc (ci)	4/3769 (230)			
47	Standard Speeds, Forward/Reverse		1/1			
48	Hydraulic Tank - capacity (drain & refill)	gal (liter)	20.5 (77.7)			
49	Auxiliary Hydraulic Pressure Relief for Attachments	PSI (Mpa)	2250 (15.5)			

CERTIFICATION: These Hyster lift trucks meet design specifications of Part II ANSI B56.1-1969, as required by OSHA Section 1910.178(a)(2) and also comply with Part III ANSI B56.1-revision in effect at time of manufacture. Certification of compliance with the applicable ANSI standards appears on the lift truck.

† NOTE: Performance specifications / ratings are for truck equipped as described under Standard Equipment in this Technical Guide. Performance specifications are affected by the condition of the vehicle and how it is equipped, as well as by the nature and condition of the operating area. Specifications are subject to change and the proposed application should be discussed with your authorized Hyster Company Dealer.

†† Limited by traction. For further information on this dimension, please contact your local Hyster dealer.

RL = Rated Load, NL = No Load

# > S120FT DIMENSIONS

GENERAL	1	Manufacturer Name		Hyster Company
	2	Model		S120FT
	3	Engine		Kubota 3.8L LPG
	4	Rated Capacity	lb (kg)	12000 (5443)
	5	Load Center, Distance	in (mm)	24 (610)
	6	Power Type		LPG
	7	Operator Type		Sit-Down Rider
	8	Step Height	in (mm)	15.6 (396)
	9	Tire Type - Cushion, Solid, Pneumatic		Cushion
DIMENSIONS	10	Wheels, Number - Front/ Rear	X driven	2x/2
	11	Lift Height, Top of Fork (TOF)	in (mm)	110 (2800)
	12	Lift Heights, Standard Limited Free Lift (LFL) with LBR (TOF)	in (mm)	6 (150)
	13	Lift Heights, Optional Full Free Lift (FFL) with LBR (TOF)	in (mm)	35 (907)
	14	Standard Carriage Width	in (mm)	42 (1067)
	15	Forks, Thickness x Width x Length	in (mm)	2.5 X 60 X 48 (60 X 150 X 1219)
	16	Fork Spread, Outside Dimensions	in (mm)	38.3 (972)
	17	Mast Tilt Angles, Forward/Backward	degrees	5F/6B
	18	Length To Face of Forks	in (mm)	112.6 (2861)
	19	Overall Width, Standard Tread	in (mm)	52.0 (1320)
	20	Overall Width, Wide Tread	in (mm)	55.9 (1420)
	21	Height, Standard Mast - Lowered	in (mm)	85 (2138)
	22	Height, Standard Mast - Extended with LBR	in (mm)	159 (4031)
	23	Height, Standard Mast - Extended without LBR	in (mm)	144 (3657)
PERFORMANCE <sup>†</sup>	24	Height, Standard Overhead Guard	in (mm)	86 (2175)
	25	Height, Optional Overhead Guard	in (mm)	83 (2108)
	26	Turning Radius, Minimum Outside (OTR)	in (mm)	99.8 (2534)
	27	Length, Center of Wheel to Face of Forks	in (mm)	18.2 (462)
	28	Aisle Width, Right Angle Stack (Add Length of Load)	in (mm)	118 (2996)
	29	Equal Aisle, 90-Degree Intersecting Aisle (48" L X 40" W Load)	in (mm)	87.8 (2230)
	30	Travel Speed RL/NL 1-Speed	mph (km/h)	10.4/10.5 (16.8/16.9)
	31	2-Speed	mph (km/h)	13.4/13.7 (21.6/22)
	32	Lift Speed, Standard 2-Stage LFL RL/NL	ft/min (m/s)	110/112 (.56/.57)
	33	Lift Speed, Optional 2-Stage FFL RL/NL	ft/min (m/s)	102/106 (.52/.54)
	34	Lift Speed, Optional 3-Stage FFL RL/NL	ft/min (m/s)	106/108 (.54/.55)
	35	Lowering Speed, Standard 2-Stage LFL RL/NL	ft/min (m/s)	100/83 (.51/.42)
	36	Lowering Speed, Optional 2-Stage FFL RL/NL	ft/min (m/s)	89/63 (.45/.32)
	37	Lowering Speed, Optional 3-Stage FFL RL/NL	ft/min (m/s)	93/77 (.47/.39)
WT.	38	Max Drawbar Pull RL/NL 1-Speed	lb (kg)	7784/3597 (3531/1631)
	39	2-Speed	lb (kg)	9363/3597 (4247/1631)
	40	Drawbar Pull @ 1 mph RL/NL 1-Speed	lb (kg)	6665/3597 (3023/1631)
	41	2-Speed	lb (kg)	7733/3597 (3508/1631)
	42	Max Gradeability RL/NL †† 1-Speed	%	28/22
	43	2-Speed	%	35/22
TIRES & WHEELS	44	Gradeability @ 1 mph RL/NL †† 1-Speed	%	24/22
	45	2-Speed	%	28/22
	46	Weight, Standard Truck (Standard 2-Stg. LFL) NL	lb (kg)	16690 (7570)
	47	Weight, Standard Truck (Standard 2-Stg. LFL) RL	lb (kg)	28690 (13014)
POWERTRAIN	48	Axle Loading, Static Front/Rear NL	lb (kg)	5995 / 10695 (2719 / 4851)
	49	Axle Loading, Static Front/Rear RL	lb (kg)	25178 / 3512 (11421 / 1593)
	50	Tire Size, Front		22 X 12 X 16
	51	Tire Size, Rear		18 X 8 X 12.2
	52	Wheelbase	in (mm)	70.5 (1790)
	53	Ground Clearance, Lowest Point NL (with RL subtract -6mm)	in (mm)	4.6 (118)
	54	Ground Clearance, Center of Wheelbase NL	in (mm)	6.1 (156)
	55	Service Brake - Method of Control/Operation		Foot/Hydraulic
	56	Parking Brake - Method of Control/Operation		Hand/Mechanical
	57	Battery Type		Maintenance Free
	58	Volts/Cold Cranking Amps	v/cca	12/475
	59	Engine, Manufacturer/Model		Kubota WG3800 LPG
	60	Permanent Output	hp (kW)	91 (69) @ 2400 RPM
	61	Torque @ Rated RPM	ft/lbs (kg/m)	221 (300) @ 1000 RPM
	62	Number of Cylinders/Displacement	No/cc (ci)	4/3769 (230)
	63	Standard Speeds, Forward/Reverse		1/1
64	Hydraulic Tank - capacity (drain & refill)	gal (liter)	20.5 (77.7)	
65	Auxiliary Hydraulic Pressure Relief for Attachments	PSI (Mpa)	2250 (15.5)	

**CERTIFICATION:** These Hyster lift trucks meet design specifications of Part II ANSI B56.1-1969, as required by OSHA Section 1910.178(a)(2) and also comply with Part III ANSI B56.1-revision in effect at time of manufacture. Certification of compliance with the applicable ANSI standards appears on the lift truck.

<sup>†</sup> NOTE: Performance specifications / ratings are for truck equipped as described under Standard Equipment in this Technical Guide. Performance specifications are affected by the condition of the vehicle and how it is equipped, as well as by the nature and condition of the operating area. Specifications are subject to change and the proposed application should be discussed with your authorized Hyster Company Dealer.

<sup>††</sup> Limited by traction. For further information on this dimension, please contact your local Hyster dealer.

RL = Rated Load, NL = No Load

# S120FTS SPECIFICATIONS <

GENERAL	1	Manufacturer Name		Hyster Company	
	2	Model		S120FTS	
		Engine		Kubota 3.8L LPG	
	3	Rated Capacity	lb (kg)	12000 (5443)	
	4	Load Center, Distance	in (mm)	24 (610)	
	5	Power Type		LPG	
	6	Operator Type		Sit-Down Rider	
	7	Step Height	in (mm)	15.6 (396)	
	8	Tire Type - Cushion, Solid, Pneumatic		Cushion	
DIMENSIONS	9	Wheels, Number - Front/ Rear	X driven	2x/2	
	10	Lift Height, Top of Fork (TOF)	in (mm)	110 (2800)	
	11	Lift Heights, Standard Limited Free Lift (LFL) with LBR (TOF)	in (mm)	6 (150)	
		Lift Heights, Optional Full Free Lift (FFL) with LBR (TOF)	in (mm)	35 (907)	
	12	Standard Carriage Width	in (mm)	42 (1067)	
	13	Forks, Thickness x Width x Length	in (mm)	2.5 X 60 X 48 (60 X 150 X 1219)	
	14	Fork Spread, Outside Dimensions	in (mm)	38.3 (972)	
	15	Mast Tilt Angles, Forward/Backward	degrees	5F/6B	
	16	Length To Face of Forks	in (mm)	106.3 (2699)	
	17	Overall Width, Standard Tread	in (mm)	52.0 (1320)	
		Overall Width, Wide Tread	in (mm)	55.9 (1420)	
	18	Height, Standard Mast - Lowered	in (mm)	85 (2138)	
	19	Height, Standard Mast - Extended with LBR	in (mm)	159 (4031)	
		Height, Standard Mast - Extended without LBR	in (mm)	144 (3657)	
	20	Height, Standard Overhead Guard	in (mm)	86 (2175)	
		Height, Optional Overhead Guard	in (mm)	83 (2108)	
	21	Turning Radius, Minimum Outside (OTR)	in (mm)	93.5 (2375)	
	22	Length, Center of Wheel to Face of Forks	in (mm)	18.2 (462)	
	23	Aisle Width, Right Angle Stack (Add Length of Load)	in (mm)	111.7 (2837)	
	24	Equal Aisle, 90-Degree Intersecting Aisle (48" L X 40" W Load)	in (mm)	86.0 (2184)	
	PERFORMANCE <sup>†</sup>	25	Travel Speed RL/NL 1-Speed	mph (km/h)	10.4/10.5 (16.8/16.9)
			2-Speed	mph (km/h)	13.4/13.7 (21.6/22)
		26	Lift Speed, Standard 2-Stage LFL RL/NL	ft/min (m/s)	110/112 (.56/.57)
			Lift Speed, Optional 2-Stage FFL RL/NL	ft/min (m/s)	102/106 (.52/.54)
		Lift Speed, Optional 3-Stage FFL RL/NL	ft/min (m/s)	106/108 (.54/.55)	
27		Lowering Speed, Standard 2-Stage LFL RL/NL	ft/min (m/s)	100/83 (.51/.42)	
		Lowering Speed, Optional 2-Stage FFL RL/NL	ft/min (m/s)	89/63 (.45/.32)	
		Lowering Speed, Optional 3-Stage FFL RL/NL	ft/min (m/s)	93/77 (.47/.39)	
28		Max Drawbar Pull RL/NL 1-Speed	lb (kg)	7783/3870 (3530/1756)	
		2-Speed	lb (kg)	9362/3870 (4247/1756)	
		Drawbar Pull @ 1 mph RL/NL 1-Speed	lb (kg)	6664/3870 (3023/1756)	
		2-Speed	lb (kg)	7732/3870 (3507/1756)	
29		Max Gradeability RL/NL †† 1-Speed	%	28/24	
		2-Speed	%	34/24	
		Gradeability @ 1 mph RL/NL †† 1-Speed	%	24/24	
	2-Speed	%	28/24		
WT.	31	Weight, Standard Truck (Standard 2-Stg. LFL) NL	lb (kg)	16743 (7594)	
		Weight, Standard Truck (Standard 2-Stg. LFL) RL	lb (kg)	28743 (13038)	
	32	Axle Loading, Static Front/Rear NL	lb (kg)	6450 / 10293 (2926 / 4669)	
		Axle Loading, Static Front/Rear RL	lb (kg)	25634 / 3109 (11627 / 1410)	
TIRES & WHEELS	33	Tire Size, Front		22 X 12 X16	
	34	Tire Size, Rear		18 X 8 X 12.2	
	35	Wheelbase	in (mm)	70.5 (1790)	
	37	Ground Clearance, Lowest Point NL (with RL subtract -6mm)	in (mm)	4.6 (118)	
	38	Ground Clearance, Center of Wheelbase NL	in (mm)	6.1 (156)	
	39	Service Brake - Method of Control/Operation		Foot/Hydraulic	
	40	Parking Brake - Method of Control/Operation		Hand/Mechanical	
POWER TRAIN	41	Battery Type		Maintenance Free	
	42	Volts/Cold Cranking Amps	v/cca	12/475	
	43	Engine, Manufacturer/Model		Kubota WG3800 LPG	
	44	Permanent Output	hp (kW)	91 (68) @ 2400 RPM	
	45	Torque @ Rated RPM	ft/lbs (kg/m)	221 (300) @ 1000 RPM	
	46	Number of Cylinders/Displacement	No/cc (ci)	4/3769 (230)	
		Standard Speeds, Forward/Reverse		1/1	
	49	Hydraulic Tank - capacity (drain & refill)	gal (liter)	20.5 (77.7)	
	51	Auxiliary Hydraulic Pressure Relief for Attachments	PSI (Mpa)	2250 (15.5)	

CERTIFICATION: These Hyster lift trucks meet design specifications of Part II ANSI B56.1-1969, as required by OSHA Section 1910.178(a)(2) and also comply with Part III ANSI B56.1-revision in effect at time of manufacture. Certification of compliance with the applicable ANSI standards appears on the lift truck.

<sup>†</sup> NOTE: Performance specifications / ratings are for truck equipped as described under Standard Equipment in this Technical Guide. Performance specifications are affected by the condition of the vehicle and how it is equipped, as well as by the nature and condition of the operating area. Specifications are subject to change and the proposed application should be discussed with your authorized Hyster Company Dealer.

<sup>††</sup> Limited by traction. For further information on this dimension, please contact your local Hyster dealer.

RL = Rated Load, NL = No Load

# > S80-100FT BCS / S120FTS DIMENSIONS

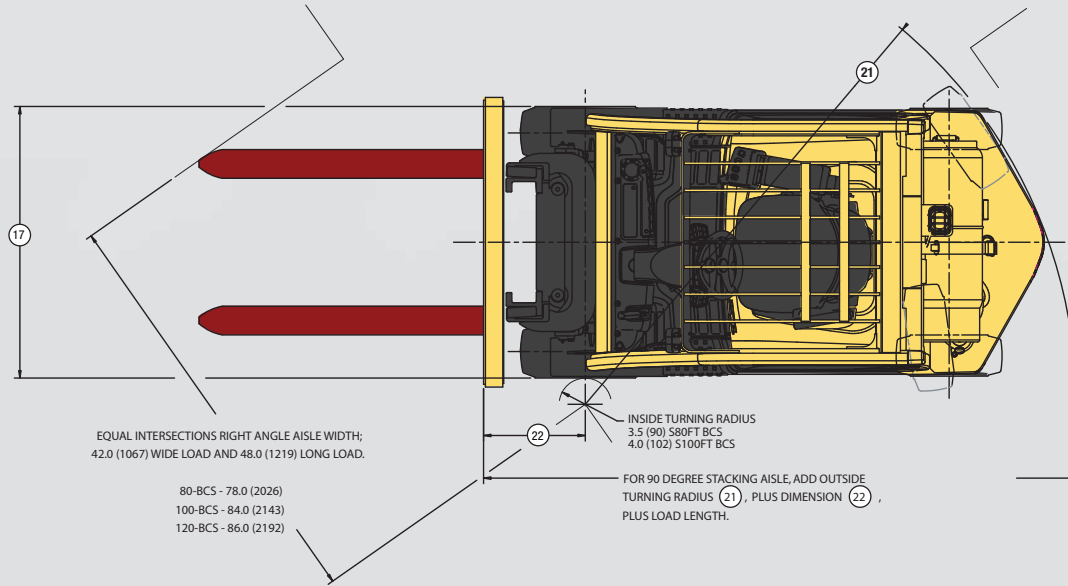

Seat Type	Standard OHG	Optional OHG
Non-Susp.	42.0 (1068)	39.4 (1001)
Semi-Susp.	42.5 (1080)	39.9 (1013)
Full-Susp.	41.8 (1062)	N/A
Swivel Full-Susp.	42.0 (1068)	N/A

TRUCK MODEL	C	D	E	T	X
	in (mm)	percent	degrees	in (mm)	in (mm)
<b>S80FT BCS</b>	16.1 (410)	44%	25.2	4.4 (112)	28.1 (714)
<b>S100FT BCS</b>	21.6 (549)	42%	22.2	5.9 (151)	28.3 (718)
<b>S120FTS</b>	17.6 (447)	37%	21	5.9 (151)	28.3 (718)

Seat in depressed position

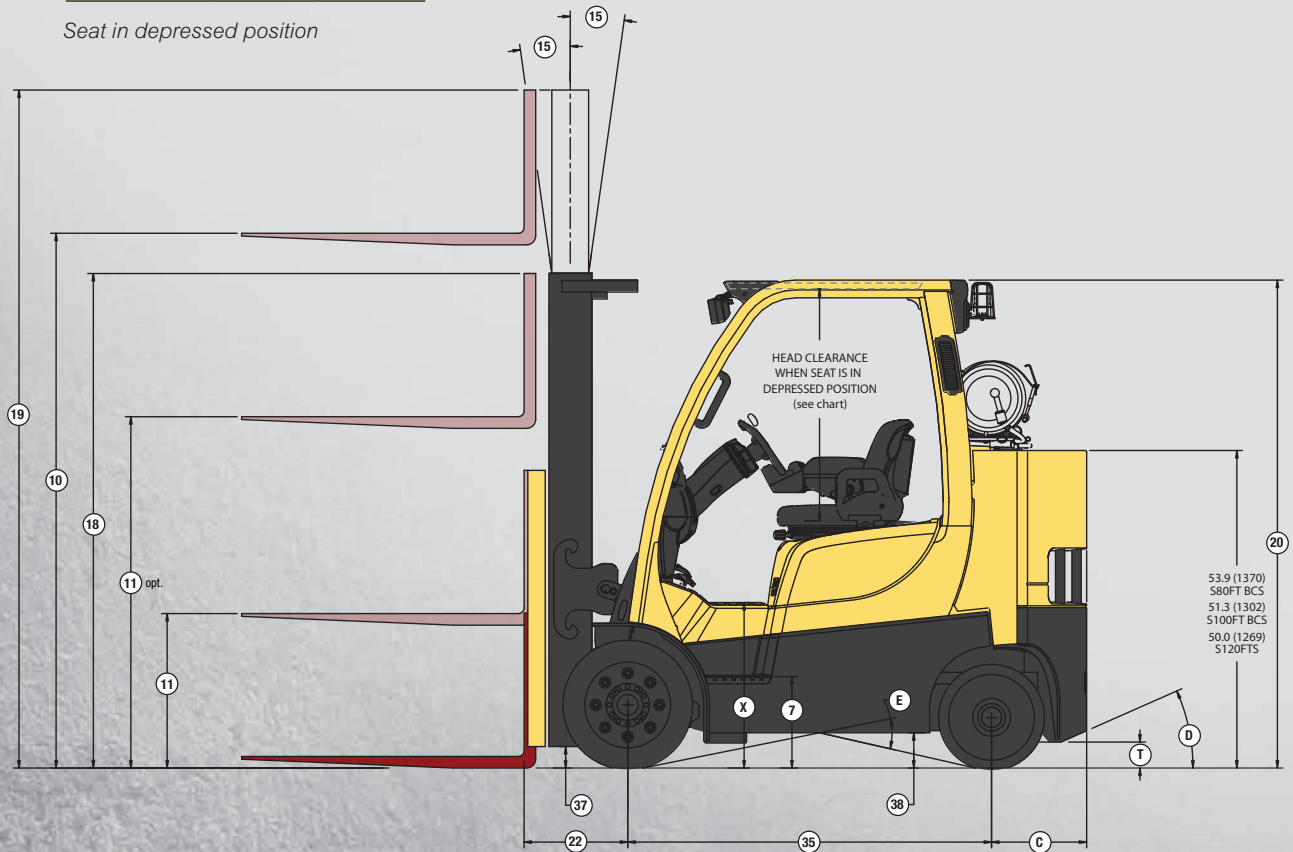

Circled dimensions correspond to the line numbers on the tabulated chart inside the Technical Guide. Dimensions are in inches (millimeters).



# S80-100FT BCS SPECIFICATIONS <

	GENERAL		DIMENSIONS		PERFORMANCE <sup>†</sup>		WT.		TIRES & WHEELS		POWERTRAIN		
	Item #	Description	Unit	S80FT BCS	100FT BCS	Unit	S80FT BCS	100FT BCS	Unit	S80FT BCS	100FT BCS	Unit	S80FT BCS
1	Manufacturer Name			Hyster Company									
2	Model			S80FT BCS	S100FT BCS								
3	Engine			Kubota 3.8L LPG									
3	Rated Capacity	lb (kg)	8000 (3629)	10000 (4536)									
4	Load Center, Distance	in (mm)	24 (610)										
5	Power Type			LPG									
6	Operator Type			Sit-Down Rider									
7	Step Height	in (mm)	15.6 (396)										
8	Tire Type - Cushion, Solid, Pneumatic			Cushion									
9	Wheels, Number - Front/ Rear	X driven	2x/2										
10	Lift Height, Top of Fork (TOF)	in (mm)	120 (3050)	110 (2800)									
11	Lift Heights, Standard Limited Free Lift (LFL) with LBR (TOF)	in (mm)	6 (150)										
	Lift Heights, Optional Full Free Lift (FFL) with LBR (TOF)	in (mm)	35 (900)										
12	Standard Carriage Width	in (mm)	42 (1067)										
13	Forks, Thickness x Width x Length	in (mm)	2 X 5 X 48 (50 X 125 X 1219)		2 X 6 X 48 (50 X 150 X 1219)								
14	Fork Spread, Outside Dimensions	in (mm)	38.3 (972)										
15	Mast Tilt Angles, Forward/Backward	degrees	5F/6B										
16	Length To Face of Forks	in (mm)	95.6 (2427)	101.2 (2571)									
17	Overall Width, Standard Tread	in (mm)	46.1 (1170)	52.0 (1320)									
	Overall Width, Wide Tread	in (mm)	50.0 (1270)	55.9 (1420)									
18	Height, Standard Mast - Lowered	in (mm)	84 (2134)	85 (2138)									
19	Height, Standard Mast - Extended with LBR	in (mm)	169 (4284)	159 (4031)									
	Height, Standard Mast - Extended without LBR	in (mm)	149 (3783)	144 (3657)									
20	Height, Standard Overhead Guard	in (mm)	86 (2171)	86 (2175)									
	Height, Optional Overhead Guard	in (mm)	83 (2104)	83 (2108)									
21	Turning Radius, Minimum Outside (OTR)	in (mm)	82.8 (2102)	87.9 (2232)									
22	Length, Center of Wheel to Face of Forks	in (mm)	17.6 (447)	17.8 (452)									
23	Aisle Width, Right Angle Stack (Add Length of Load)	in (mm)	100.4 (2549)	105.7 (2684)									
24	Equal Aisle, 90-Degree Intersecting Aisle (48" L X 40" W Load)	in (mm)	79.4 (2017)	84.1 (2136)									
25	Travel Speed RL/NL 1-Speed	mph (km/h)	10.7/10.7 (17.2/17.2)	10.5/10.5 (16.9/17)									
		2-Speed	mph (km/h)	13.7/13.9 (22.1/22.4)	13.5/13.7 (21.7/22.1)								
26	Lift Speed, Standard 2-Stage LFL RL/NL	ft/min (m/s)	120/122 (.61/.62)	110/112 (.56/.57)									
		Lift Speed, Optional 2-Stage FFL RL/NL	ft/min (m/s)	106/108 (.54/.55)	102/106 (.52/.54)								
	Lift Speed, Optional 3-Stage FFL RL/NL	ft/min (m/s)	112/114 (.57/.58)	106/108 (.54/.55)									
27	Lowering Speed, Standard 2-Stage LFL RL/NL	ft/min (m/s)	93/108 (.47/.55)	100/83 (.51/.42)									
		Lowering Speed, Optional 2-Stage FFL RL/NL	ft/min (m/s)	71/98 (.36/.50)	89/63 (.45/.32)								
	Lowering Speed, Optional 3-Stage FFL RL/NL	ft/min (m/s)	87/104 (.44/.53)	93/77 (.47/.39)									
28	Max Drawbar Pull RL/NL 1-Speed	lb (kg)	7118/3333 (3229/1512)	7835/3328 (3554/1510)									
		2-Speed	lb (kg)	8550/3333 (3878/1512)	9413/3328 (4270/1510)								
	Drawbar Pull @ 1 mph RL/NL 1-Speed	lb (kg)	6159/3333 (2794/1512)	6715/3328 (3046/1510)									
	2-Speed	lb (kg)	7148/3333 (3242/1512)	7783/3328 (3531/1510)									
29	Max Gradeability RL/NL †† 1-Speed	%	35/26	31/21									
		2-Speed	%	44/26	39/21								
	Gradeability @ 1 mph RL/NL †† 1-Speed	%	30/26	27/21									
	2-Speed	%	36/26	31/21									
31	Weight, Standard Truck (Standard 2-Stg. LFL) NL	lb (kg)	13340 (6051)	16164 (7332)									
		Weight, Standard Truck (Standard 2-Stg. LFL) RL	lb (kg)	21340 (9680)	26164 (11868)								
32	Axle Loading, Static Front/Rear NL	lb (kg)	5555 / 7785 (2520 / 3531)	5546 / 10618 (2516 / 4816)									
		Axle Loading, Static Front/Rear RL	lb (kg)	18940 / 2400 (8591 / 1089)	22373 / 3791 (10148 / 1720)								
33	Tire Size, Front	22 X 9 X16		22 X 12 X16									
34	Tire Size, Rear	18 X 7 X 12.2		18 X 8 X 12.2									
35	Wheelbase	in (mm)	61.8 (1570)										
37	Ground Clearance, Lowest Point NL (with RL subtract -6mm)	in (mm)	4.5 (114)										
38	Ground Clearance, Center of Wheelbase NL	in (mm)	6.0 (152)										
39	Service Brake - Method of Control/Operation			Foot/Hydraulic									
40	Parking Brake - Method of Control/Operation			Hand/Mechanical									
41	Battery Type			Maintenance Free									
42	Volts/Cold Cranking Amps			12/475									
43	Engine, Manufacturer/Model			Kubota WG3800 LPG									
44	Permanent Output	hp (kW)	74 (55) @ 1800 RPM	91 (68) @ 2400 RPM									
45	Torque @ Rated RPM	ft/lbs (kg/m)	221 (300) @ 1000 RPM										
46	Number of Cylinders/Displacement	No/cc (ci)	4/3769 (230)										
	Standard Speeds, Forward/Reverse			1/1									
49	Hydraulic Tank - capacity (drain & refill)	gal (liter)	20.5 (77.7)										
51	Auxiliary Hydraulic Pressure Relief for Attachments	PSI (Mpa)	2250 (15.5)										

CERTIFICATION: These Hyster lift trucks meet design specifications of Part II ANSI B56.1-1969, as required by OSHA Section 1910.178(a)(2) and also comply with Part III ANSI B56.1-revision in effect at time of manufacture. Certification of compliance with the applicable ANSI standards appears on the lift truck.

† NOTE: Performance specifications / ratings are for truck equipped as described under Standard Equipment in this Technical Guide. Performance specifications are affected by the condition of the vehicle and how it is equipped, as well as by the nature and condition of the operating area. Specifications are subject to change and the proposed application should be discussed with your authorized Hyster Company Dealer.

†† Limited by traction. For further information on this dimension, please contact your local Hyster dealer.

RL = Rated Load, NL = No Load

# > S120FT PRS DIMENSIONS

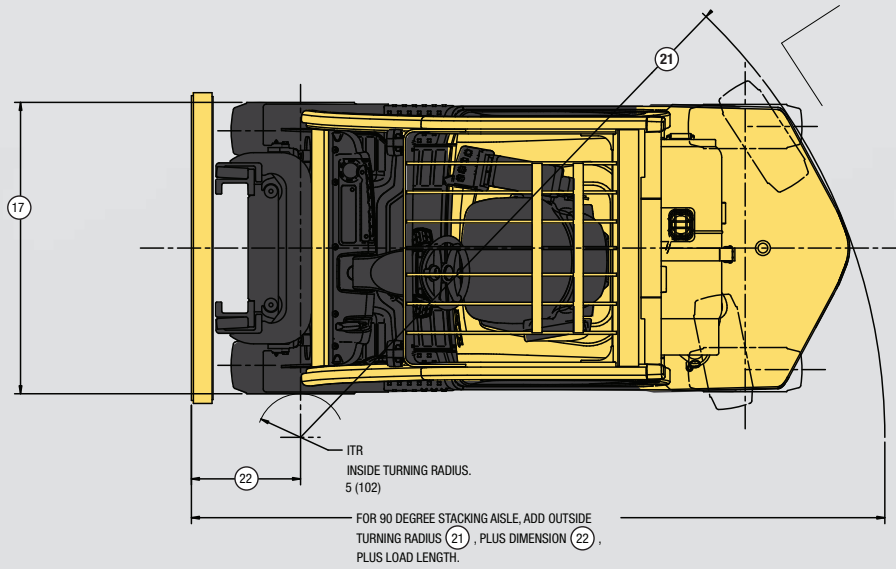

TRUCK MODEL	C	D	E	T	X
	in (mm)	percent	degrees	in (mm)	in (mm)
S120FT PRS	17.6 (447)	37%	21	6 (151)	28.2 (718)

Seat Type	Standard OHG	Optional OHG
Non-Suspension	42.0 (1068)	39.4 (1001)
Semi-Suspension	42.5 (1080)	39.9 (1013)
Full-Suspension	41.8 (1062)	N/A
Swivel Full-Suspension	42.0 (1068)	N/A

Seat in depressed position

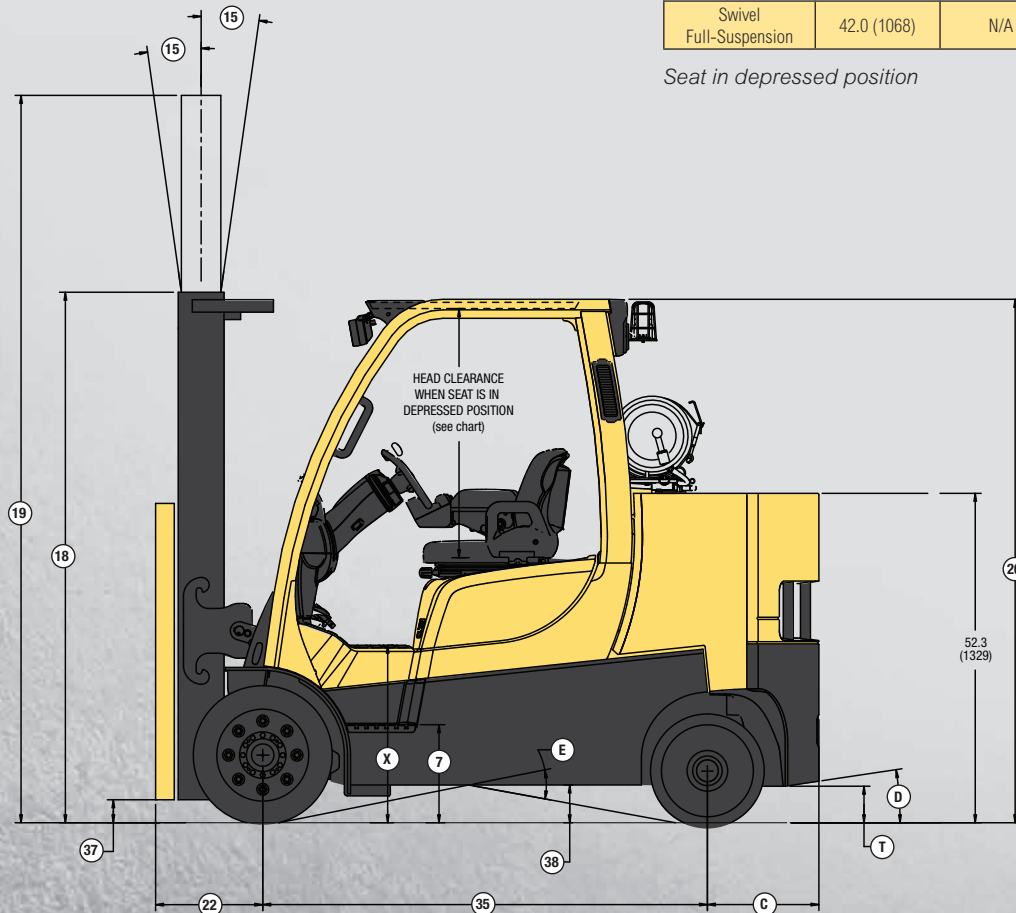

Circled dimensions correspond to the line numbers on the tabulated chart inside the Technical Guide. Dimensions are in inches (millimeters).

# S120FT PRS SPECIFICATIONS <

GENERAL	1	Manufacturer Name		Hyster Company
	2	Model		S120FT PRS
		Engine		Kubota 3.8L LPG
	3	Rated Capacity	lb (kg)	12000 (5443)
	4	Load Center, Distance	in (mm)	24 (610)
	5	Power Type		LPG
	6	Operator Type		Sit-Down Rider
	7	Step Height	in (mm)	15.6 (396)
	8	Tire Type - Cushion, Solid, Pneumatic		Cushion
DIMENSIONS	9	Wheels, Number - Front/ Rear	X driven	2x/2
	10	Lift Height, Top of Fork (TOF)	in (mm)	N/A
	11	Lift Heights, Standard Limited Free Lift (LFL) with LBR (TOF)	in (mm)	N/A
		Lift Heights, Optional Full Free Lift (FFL) with LBR (TOF)	in (mm)	N/A
	12	Standard Carriage Width	in (mm)	42 (1067)
	13	Forks, Thickness x Width x Length	in (mm)	N/A
	14	Fork Spread, Outside Dimensions	in (mm)	N/A
	15	Mast Tilt Angles, Forward/Backward	degrees	5F/6B
	16	Length To Face of Forks	in (mm)	N/A
	17	Overall Width, Standard Tread	in (mm)	52.0 (1320)
		Overall Width, Wide Tread	in (mm)	55.9 (1420)
	18	Height, Standard Mast - Lowered	in (mm)	85 (2138)
	19	Height, Standard Mast - Extended with LBR	in (mm)	159 (4031)
		Height, Standard Mast - Extended without LBR	in (mm)	144 (3657)
PERFORMANCE <sup>†</sup>	20	Height, Standard Overhead Guard	in (mm)	86 (2175)
		Height, Optional Overhead Guard	in (mm)	83 (2108)
	21	Turning Radius, Minimum Outside (OTR)	in (mm)	93.5 (2375)
	22	Length, Center of Wheel to Face of Forks	in (mm)	N/A
	23	Aisle Width, Right Angle Stack (Add Length of Load)	in (mm)	N/A
	24	Equal Aisle, 90-Degree Intersecting Aisle (48" L X 40" W Load)	in (mm)	N/A
	25	Travel Speed RL/NL 1-Speed	mph (km/h)	10.4/10.5 (16.8/16.9)
			2-Speed	13.4/13.7 (21.5/22)
		Lift Speed, Standard 2-Stage LFL RL/NL	ft/min (m/s)	110/112 (.56/.57)
			Lift Speed, Optional 2-Stage FFL RL/NL	ft/min (m/s)
		Lift Speed, Optional 3-Stage FFL RL/NL	ft/min (m/s)	106/108 (.54/.55)
			Lowering Speed, Standard 2-Stage LFL RL/NL	ft/min (m/s)
		Lowering Speed, Optional 2-Stage FFL RL/NL		ft/min (m/s)
			Lowering Speed, Optional 3-Stage FFL RL/NL	ft/min (m/s)
28		Max Drawbar Pull RL/NL 1-Speed		lb (kg)
			2-Speed	9336/4064 (4235/1843)
	Drawbar Pull @ 1 mph RL/NL 1-Speed	lb (kg)	6637/4064 (3011/1843)	
		2-Speed	7705/4064 (3495/1843)	
29	Max Gradeability RL/NL †† 1-Speed	%	27/23	
		2-Speed	33/23	
	Gradeability @ 1 mph RL/NL †† 1-Speed	%	23/23	
		2-Speed	26/23	
WT.	31	Weight, Standard Truck (Standard 2-Stg. LFL) NL	lb (kg)	18155 (8235)
		Weight, Standard Truck (Standard 2-Stg. LFL) RL	lb (kg)	30155 (13678)
	32	Axle Loading, Static Front/Rear NL	lb (kg)	6773 / 11382 (3072 / 5163)
			lb (kg)	25957 / 4198 (11774 / 1904)
TIRES & WHEELS	33	Tire Size, Front		22 X 12 X16
	34	Tire Size, Rear		18 X 8 X 12.2
	35	Wheelbase	in (mm)	70.5 (1790)
	37	Ground Clearance, Lowest Point NL (with RL subtract -6mm)	in (mm)	4.6 (118)
	38	Ground Clearance, Center of Wheelbase NL	in (mm)	6.1 (156)
	39	Service Brake - Method of Control/Operation		Foot/Hydraulic
	40	Parking Brake - Method of Control/Operation		Hand/Mechanical
POWER TRAIN	41	Battery Type		Maintenance Free
	42	Volts/Cold Cranking Amps	v/cca	12/475
	43	Engine, Manufacturer/Model		Kubota WG3800 LPG
	44	Permanent Output	hp (kW)	91 (68) @ 2400 RPM
	45	Torque @ Rated RPM	ft/lbs (kg/m)	221 (300) @ 1000 RPM
	46	Number of Cylinders/Displacement	No/cc (ci)	4/3769 (230)
		Standard Speeds, Forward/Reverse		1/1
	49	Hydraulic Tank - capacity (drain & refill)	gal (liter)	20.5 (77.7)
	51	Auxiliary Hydraulic Pressure Relief for Attachments	PSI (Mpa)	2250 (15.5)

CERTIFICATION: These Hyster lift trucks meet design specifications of Part II ANSI B56.1-1969, as required by OSHA Section 1910.178(a)(2) and also comply with Part III ANSI B56.1-revision in effect at time of manufacture. Certification of compliance with the applicable ANSI standards appears on the lift truck.

<sup>†</sup> NOTE: Performance specifications / ratings are for truck equipped as described under Standard Equipment in this Technical Guide. Performance specifications are affected by the condition of the vehicle and how it is equipped, as well as by the nature and condition of the operating area. Specifications are subject to change and the proposed application should be discussed with your authorized Hyster Company Dealer.

<sup>††</sup> Limited by traction. For further information on this dimension, please contact your local Hyster dealer.

RL = Rated Load, NL = No Load

# > MAST DIMENSIONS

<b>S80FT/S80FT BCS MAST DIMENSIONS</b>					
Maximum Fork Height (TOF) †	Overall Lowered Height	Overall Extended Height		Free-Lift (TOF)	
		w/ Load Backrest	w/o Load Backrest	w/ Load Backrest	w/o Load Backrest
in (mm)	in (mm)	in (mm)	in (mm)	in (mm)	in (mm)
<b>2-STAGE LIMITED FREE-LIFT (LFL) VISTA™ MAST</b>					
120 (3050)	85 (2134)	169 (4284)	149 (3783)	5 (150)	5 (150)
143 (3650)	96 (2434)	193 (4897)	193 (4884)	5 (150)	5 (150)
<b>2-STAGE FULL FREE-LIFT (FFL) VISTA™ MAST</b>					
121 (3075)	85 (2134)	170 (4309)	152 (3857)	35 (900)	53 (1352)
<b>3-STAGE FULL FREE-LIFT (FFL) VISTA™ MAST</b>					
173 (4415)	85 (2134)	223 (5649)	205 (5197)	35 (900)	53 (1352)
185 (4715)	88 (2234)	235 (5949)	217 (5497)	39 (1000)	57 (1452)
194 (4950)	92 (2334)	244 (6184)	226 (5732)	43 (1100)	61 (1552)
218 (5550)	100 (2534)	268 (6784)	250 (6332)	51 (1300)	68 (1752)

<b>S100FT/S100FT BCS MAST DIMENSIONS</b>					
Maximum Fork Height (TOF) †	Overall Lowered Height	Overall Extended Height		Free-Lift (TOF)	
		w/ Load Backrest	w/o Load Backrest	w/ Load Backrest	w/o Load Backrest
in (mm)	in (mm)	in (mm)	in (mm)	in (mm)	in (mm)
<b>2-STAGE LIMITED FREE-LIFT (LFL) VISTA™ MAST</b>					
110 (2800)	85 (2138)	159 (4031)	144 (3657)	6 (160)	6 (160)
133 (3400)	96 (2438)	183 (4631)	168 (4257)	6 (160)	6 (160)
157 (4000)	108 (2738)	206 (5231)	192 (4857)	6 (160)	6 (160)
<b>2-STAGE FULL FREE-LIFT (FFL) VISTA™ MAST</b>					
111 (2825)	85 (2138)	160 (4056)	147 (3731)	35 (907)	48 (1232)
134 (3425)	96 (2438)	184 (4656)	171 (4331)	47 (1207)	60 (1532)
<b>3-STAGE FULL FREE-LIFT (FFL) VISTA™ MAST</b>					
163 (4147)	85 (2138)	212 (5378)	200 (5058)	35 (907)	48 (1227)
185 (4700)	92 (2338)	234 (5931)	221 (5611)	43 (1107)	56 (1427)
208 (5300)	100 (2538)	258 (6531)	245 (6211)	51 (1307)	64 (1627)

† Lift heights over 171.5" (4356 mm) maximum fork height are considered highlifts and require reduced capacity and restricted back tilt. Total approximate weights listed include mast, standard carriage, load backrest and 70 lbs. LP tank and tank bracket.  
 RL = Rated Load      NL = No Load

<b>S120FT/S120FTS MAST DIMENSIONS</b>					
Maximum Fork Height (TOF) †	Overall Lowered Height	Overall Extended Height		Free-Lift (TOF)	
		w/ Load Backrest	w/o Load Backrest	w/ Load Backrest	w/o Load Backrest
in (mm)	in (mm)	in (mm)	in (mm)	in (mm)	in (mm)
<b>2-STAGE LIMITED FREE-LIFT (LFL) VISTA™ MAST</b>					
110 (2800)	85 (2138)	159 (4031)	144 (3657)	6 (160)	6 (160)
133 (3400)	96 (2438)	183 (4631)	168 (4257)	6 (160)	6 (160)
157 (4000)	108 (2738)	206 (5231)	192 (4857)	6 (160)	6 (160)
<b>2-STAGE FULL FREE-LIFT (FFL) VISTA™ MAST</b>					
111 (2825)	85 (2138)	160 (4056)	147 (3731)	35 (907)	48 (1232)
134 (3425)	96 (2438)	184 (4656)	171 (4331)	47 (1207)	60 (1532)
<b>3-STAGE FULL FREE-LIFT (FFL) VISTA™ MAST</b>					
163 (4147)	85 (2138)	212 (5378)	200 (5058)	35 (907)	48 (1227)
185 (4700)	92 (2338)	234 (5931)	221 (5611)	43 (1107)	56 (1427)
208 (5300)	100 (2538)	258 (6531)	245 (6211)	51 (1307)	64 (1627)

<b>S120FT PRS MAST DIMENSIONS</b>					
Maximum Fork Height (TOF) †	Overall Lowered Height	Overall Extended Height		Free-Lift (TOF)	
		w/ Load Backrest	w/o Load Backrest	w/ Load Backrest	w/o Load Backrest
in (mm)	in (mm)	in (mm)	in (mm)	in (mm)	in (mm)
<b>2-STAGE LIMITED FREE-LIFT (LFL) VISTA™ MAST</b>					
110 (2800)	85 (2138)	N/A	144 (3657)	N/A	6 (160)
133 (3400)	96 (2438)	N/A	168 (4257)	N/A	6 (160)
157 (4000)	108 (2738)	N/A	192 (4857)	N/A	6 (160)
<b>2-STAGE FULL FREE-LIFT (FFL) VISTA™ MAST</b>					
111 (2825)	85 (2138)	N/A	147 (3731)	N/A	48 (1232)
134 (3425)	96 (2438)	N/A	171 (4331)	N/A	60 (1532)
<b>3-STAGE FULL FREE-LIFT (FFL) VISTA™ MAST</b>					
163 (4147)	85 (2138)	N/A	200 (5058)	N/A	48 (1227)
185 (4700)	92 (2338)	N/A	221 (5611)	N/A	56 (1427)
208 (5300)	100 (2538)	N/A	245 (6211)	N/A	64 (1627)

† Lift heights over 171.5" (4356 mm) maximum fork height are considered highlifts and require reduced capacity and restricted back tilt. Total approximate weights listed include mast, standard carriage, load backrest and 70 lbs. LP tank and tank bracket.  
 RL = Rated Load      NL = No Load

## > STANDARD FEATURES AND OPTIONS

### STANDARD EQUIPMENT

- Kubota 3.8L, 4 cylinder spark ignited engine
- 1 speed powershift transmission
- Electronic inching
- Heavy duty premium wet disc brakes
- MONOTROL® pedal
- 2-stage limited free-lift (LFL) VISTA™ mast with maximum fork height of 133" (2400 mm)
- 48.0" (1219 mm) wide hook-type carriage with 48.0" (1219) tall load backrest extension
- 48.0" (1219 mm) long forks
- 6 degrees forward and 10 degrees backward mast tilt
- 3-function hydraulic control valve
- Integrated dashboard display includes:
- LCD display:
  - Fuel level (diesel only)
  - Hour meter
  - Coolant temperature
  - Clock
  - Messages
- Service indicator lights:
  - Alternator
  - Transmission oil temperature
  - Engine oil pressure
  - Brake fluid level
  - Fasten seat belt
  - Low fuel level
  - Engine malfunction
  - System malfunction
  - Park brake
  - Coolant temperature
  - Forward, reverse and neutral direction indicators
- Hydrostatic power steering
- Non-suspension vinyl seat
- No-cinch seat belt
- Electronic horn
- Adjustable steer column
- Rubber floor mat
- High air intake
- Integral tie downs
- Operator restraint system
- Combi-cooler radiator
- Single pedal inch brake
- Cowl-mounted hydraulic control levers
- Swing out LPG tank bracket

### OPTIONAL EQUIPMENT

- DuraMatch 2 speed electronically controlled transmission
- Electronic inching
- Electronic shift control
- Controlled roll back on ramps
- Controlled power reversal
- Auto deceleration
- LED lights (brake/tail/back-up)
- Powertrain protection system
- Premium monitoring
- High air intake with precleaner
- Accumulator
- Keyless start (with auxiliary key switch)
- Dual LPG tank bracket
- Return to set tilt
- TouchPoint hydraulic mini-levers with fully adjustable armrest
- Rear drive handle with horn button
- Full suspension seat - vinyl or cloth
- Swivel full-suspension seat - vinyl or cloth
- High-visibility non-cinch seat belt with or without interlock
- Impact monitor with immediate or delayed shutdown
- Load weight display
- Operator pre-shift checklist
- Dual-inch brake pedals
- Operator password protection
- Audible reverse activated 82-102 dB(A) self-adjusting alarm
- Visible amber LED strobe light - continuously activated, overhead guard mounted
- Parts publications - printed or CD, serial number specific
- UL Classification D, LPS, DS
- Various light packages available with halogen or high intensity LED:
  - Two front and one rear work lights
  - Two front, one rear work light and two brake/tail/back-up lights





Hyster Company  
P.O. Box 7006  
Greenville, North Carolina  
27835-7006  
Part No. S80-120FT/TG  
1/2020 Litho in U.S.A.

Visit us online at [www.hyster.com](http://www.hyster.com) or call us at **1-800-HYSTER-1**.

Hyster, , and STRONG PARTNERS. TOUGH TRUCKS. and MONOTROL are registered trademarks in the United States and certain other jurisdictions. Hyster products are subject to change without notice.

Trucks may be shown with optional equipment. © 2020 Hyster Company. All rights reserved.